

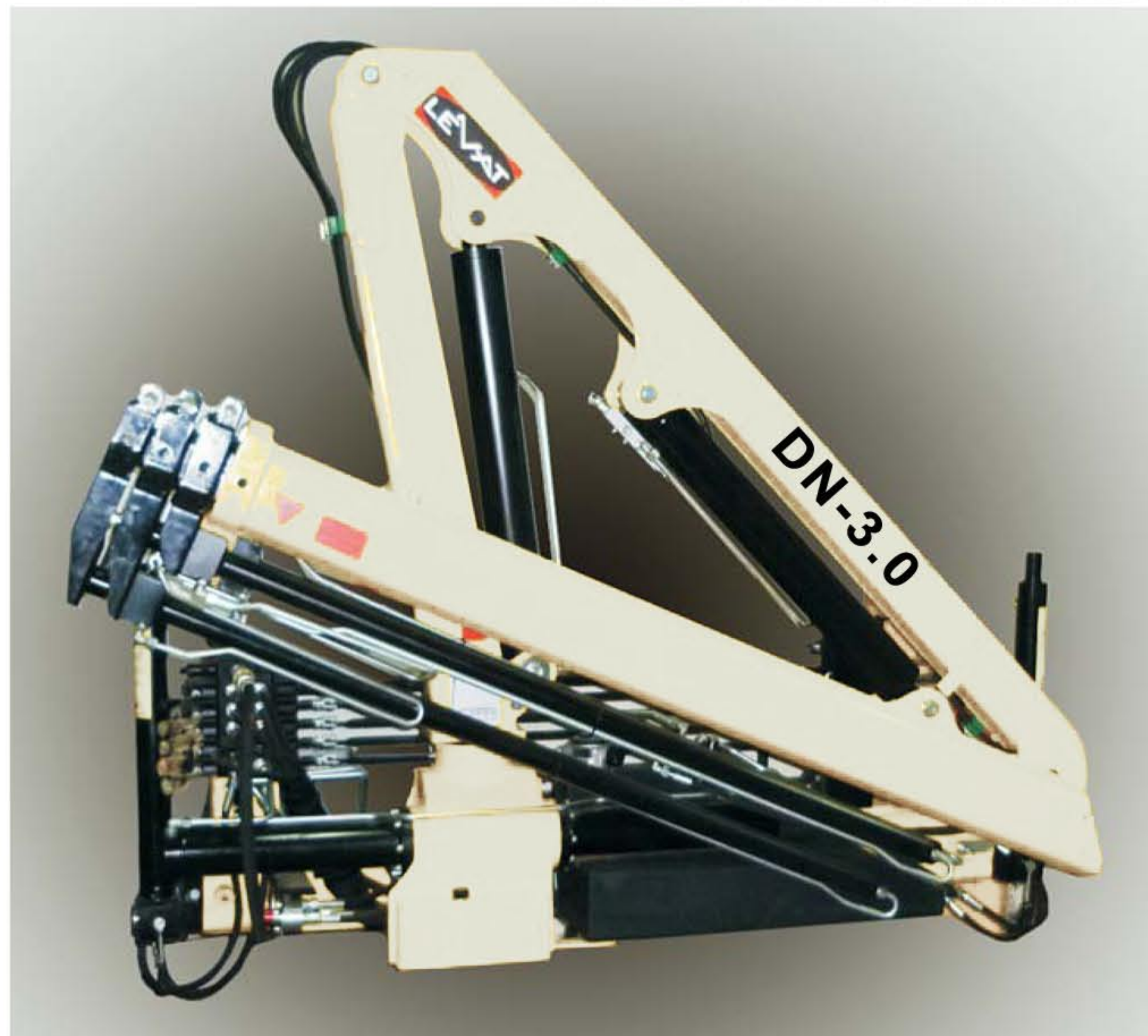

DALL'AGLIO-NORDIN GROUP



DN-3.0

TECHNICAL DESCRIPTION

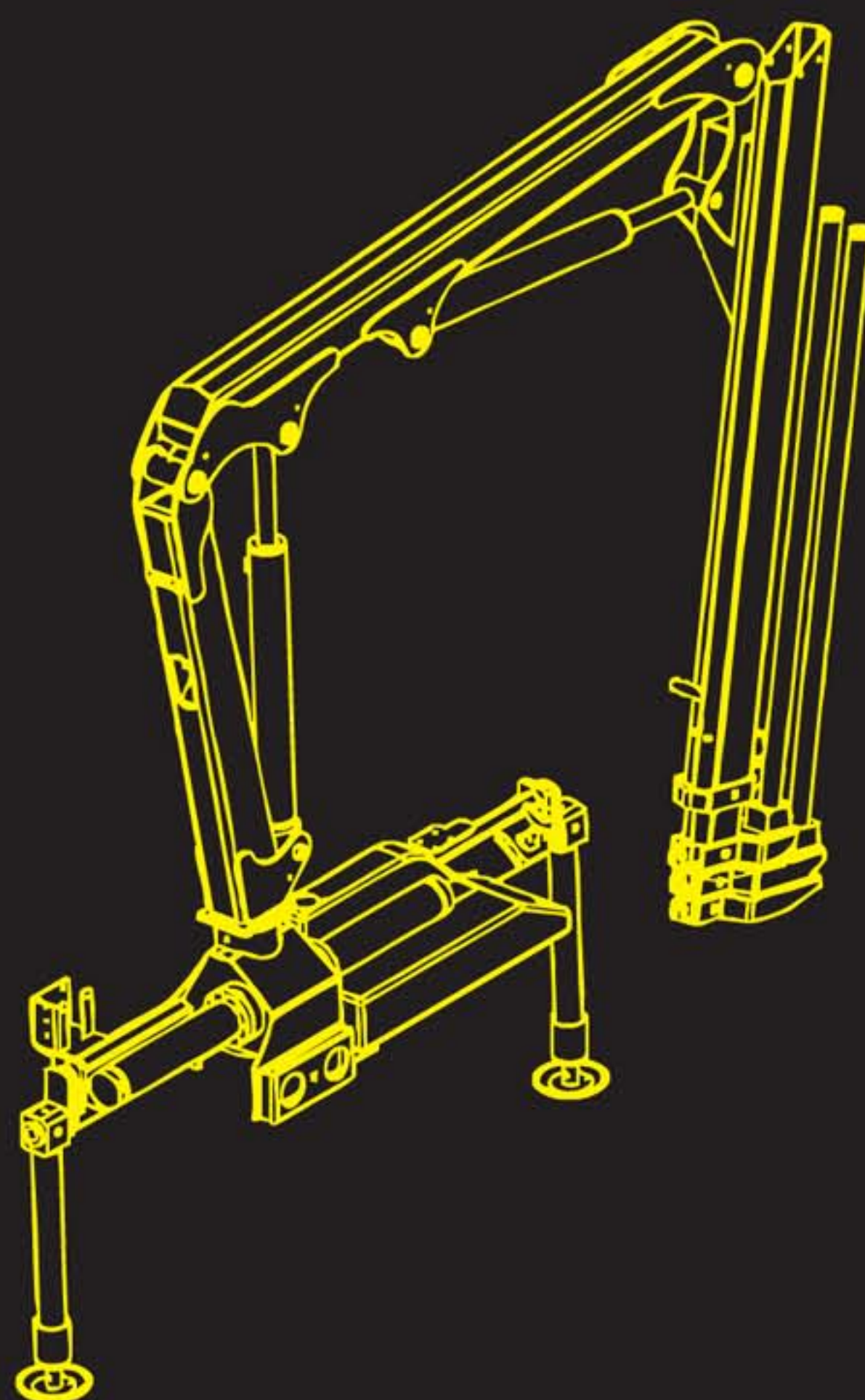

- New concept product, extremely elaborate with advanced design
- 3 Hydraulic extensions maximum and manual extension (optional)
- Lightweight – starting from 375 kg Including stabilizers
- Compact version available 1.70 m wide fits on short cab trucks
- Large opening stabilizers to install on all 3.5 ton trucks
- O-Ring oil joints
- Proportional distributor
- Slewing legs
- Flanges valves on the cylinders
- Anti-Corrosion treatment on all pins, joints and pipes
- Thermo-Resistant Steel Oil tank
- Additional Options:
 - Distributor with 2 extra functions allows Rotor and accessory
 - PLE kit fully mounted and factory tested
 - Remote control
 - Winches



www.levatcranes.com
info@levatcranes.com

Caratteristiche prodotto

- Prodotto di nuova progettazione estremamente curato e dal design evoluto
- 3 sfilii idraulici più eventuale prolunga manuale
- Superleggera : a partire da 375 kg comprese aste e stabilizzatori
- Versione C (compact) con larghezza massima 1700 mm per veicoli cabina stretta
- Allargamento stabilizzatori maggiorato per installazione a norma su qualsiasi autocarro 3,5 ton
- Raccordi olio con O-ring
- Distributore proporzionale
- Stabilizzatori rotanti (optional)
- Carpenteria interamente sabbiata
- Verniciatura di alta qualità
- Valvole flangiate sui cilindri
- Tubi, perni e raccordi con trattamento Anticorrosione
- Robustissimo serbatoio olio in acciaio saldabile dissipante il calore
- Optional: 2 attivazioni supplementari in punta per rotore e attrezzo, kit PLE completamente montato e collaudato in fabbrica, radiocomandi, argani e ogni tipo di accessorio



Caracteristique du Produit

- Produit de nouvelle conception extrêmement soigné et au design avantgardiste
- Jusque 3 extensions hydrauliques et éventuelle rallonge manuelle
- Très léger: à partir de 375 kg y compris les pieds stabilisateurs
- Version "C" compact pour camion étroit: largeur maximale de 1.70 m
- Ecartement stabilisateurs majoré pour installation sur camion 3.5 t
- Raccords huile O-ring
- Distributeur proportionnel
- Stabilisateurs rotatifs en option
- Structure de la grue entièrement sablée
- Valves flasquées sur les vérins
- Tuyaux, axes et raccords traités anticorrosion
- Réservoir en matériel synthétique thermorésistant
- Options disponibles:
 - Distributeur activés pour 2 éléments supplémentaires Rotor et Accessoire
 - Kit PLE monté et homologué en usine
 - Radiocommande
 - Treuil

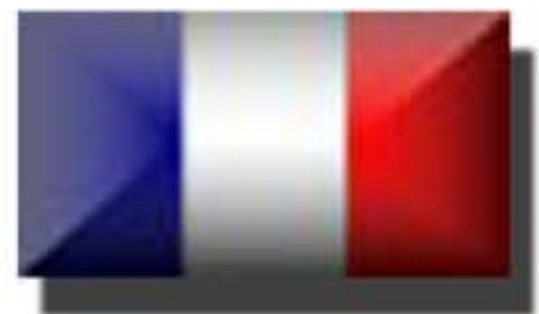

Basis Daten

- Neues extrem sorgfältiges Produkt mit kunstvoll gearbeitetem Design
- Bis drei hydraulischen Ausschüben und optional manuelle Armverlängerung
- Sehr leicht: ab 375 kg mit den Abstützungen.
- "C" (Kompakt) Version mit Maximalbreite von 1700mm für schmale Lastkraftwagen
- Abstützbreite, um das Montage auf alle 3.5 t LKW zu optimieren
- Ölanschlussgewinde mit O-Ring
- Proportionalsteuerblock
- Optional : schwenkbare Abstützungen
- Kranstahlbauteile werden alle sandstrahlt
- Zylinder mit Ventilen ausgerüstet
- Achse und Schläuche sind gegen Korrosion geschützt
- Verfügbare Optionen:
 - Distributor zwei Extrainstrumenten, die für einen Rotor und Zubehörteil aktiviert sind
 - Einrichtung einer von der Fabrik anerkannten Kit PLE (Mobile elevating work platforms) Ausrüstung
 - Funkfernsteuerung
 - Seilwinde



Características del Producto

- Producto novedoso con un diseño vanguardista y materiales de alta calidad
- Un máximo de 3 extensiones hidráulicas con la opción a una extensión adicional manual
- Ligera – a partir de 375 kg. incluyendo estabilizadores
- Versión "C" compacta disponible (1.70 m de ancho) Permite instalarse en camiones pequeños
- Estabilizadores suficientemente anchos para poder instalarse en camiones desde 3.5 toneladas
- Empalmes con O-Ring
- Distribuidor Proporcional
- Tratamiento con sandblast en toda la estructura
- Gatos estabilizadores rotatorios (opcionales)
- Válvulas de bloqueo en todos los cilindros
- Tratamiento anti-corrosivo en todos los ejes, empalmes y tuberías
- Tanque de aceite en material sintético termo resistente
- Opciones adicionales:
 - Distribuidor con 2 funciones extras Rotor / Accesorio
 - Kit PLE instalado y certificado en planta
 - Radio control
 - Cabrestante



STANDARD CRANE



Standard Outrigger Beams

- Brazos estabilizadores estándar • Bras de stabilisation standard
- Standardstützarme • Bracci stabilizzatori standard

2.7 m

Rotation Angle

- Ángulo de rotación • Angle de rotation
- Schwenkbereich • Angolo di rotazione

365°

Tierods About Anchorage

- Tirantes de fijación • Ancrage de fixation
- Zugstangen Verankerzubehörs • Tiranti di ancoraggio

n° 6 M18 x 1.5
mat. 39 NiCrMo3

Recommended Oil Flow

- Caudal requerido • Débit recommandé
- Empfohlene Fördermenge • Portata raccomandata

10 l/min

Oil Tank Capacity

- Capacidad del tanque de aceite • Capacité du réservoir d'huile
- Öl Tankinhalt • Capacità del serbatoio

30 L / 7.9 gal

Maximum Pressure

- Presión máxima • Pression maximum
- Maximal zulässiger Betriebsdruck • Pressione massima

270 bar / 3,916 psi

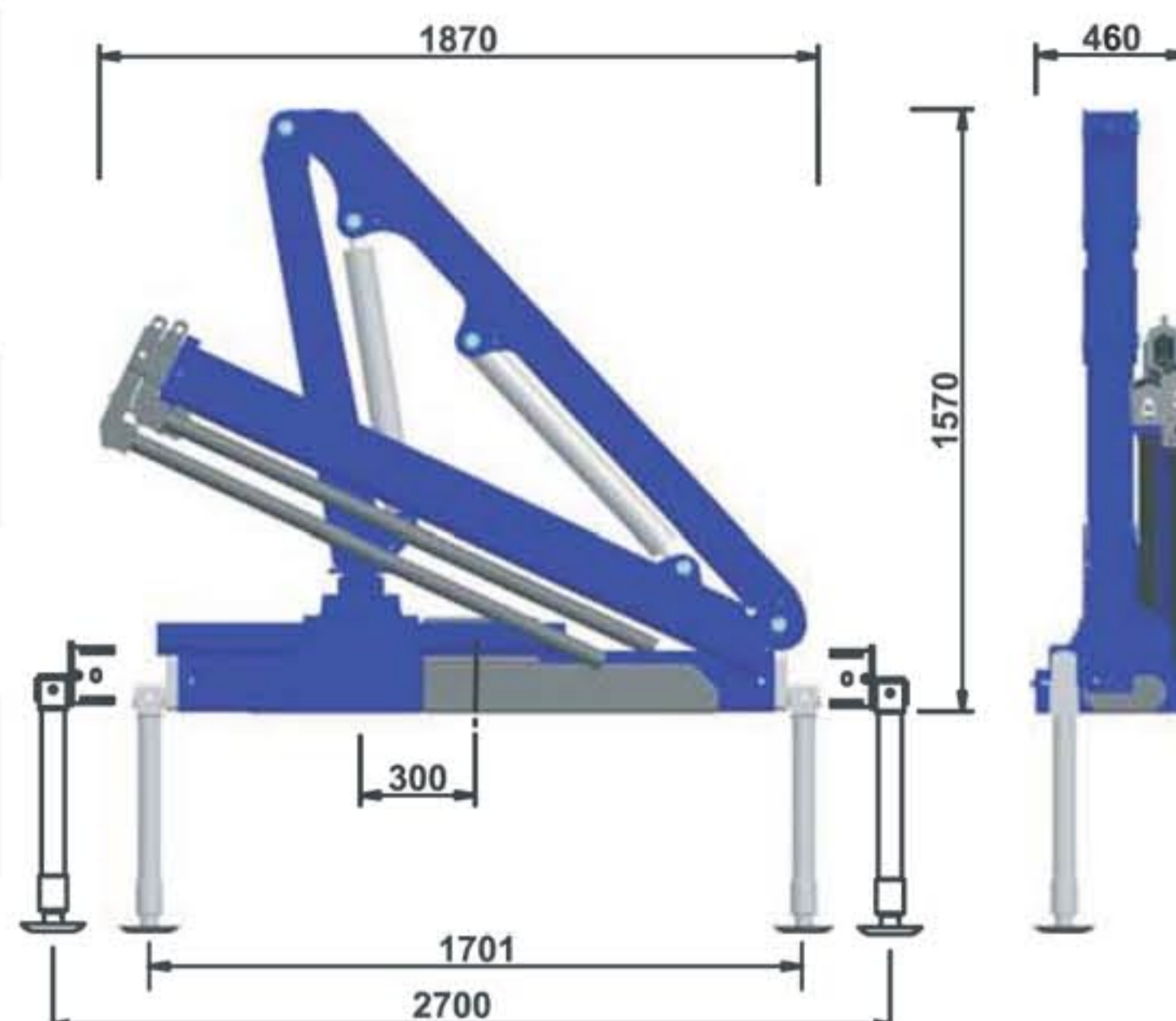

Range Diagram & Lifting Capacity

DN 3.0-S1

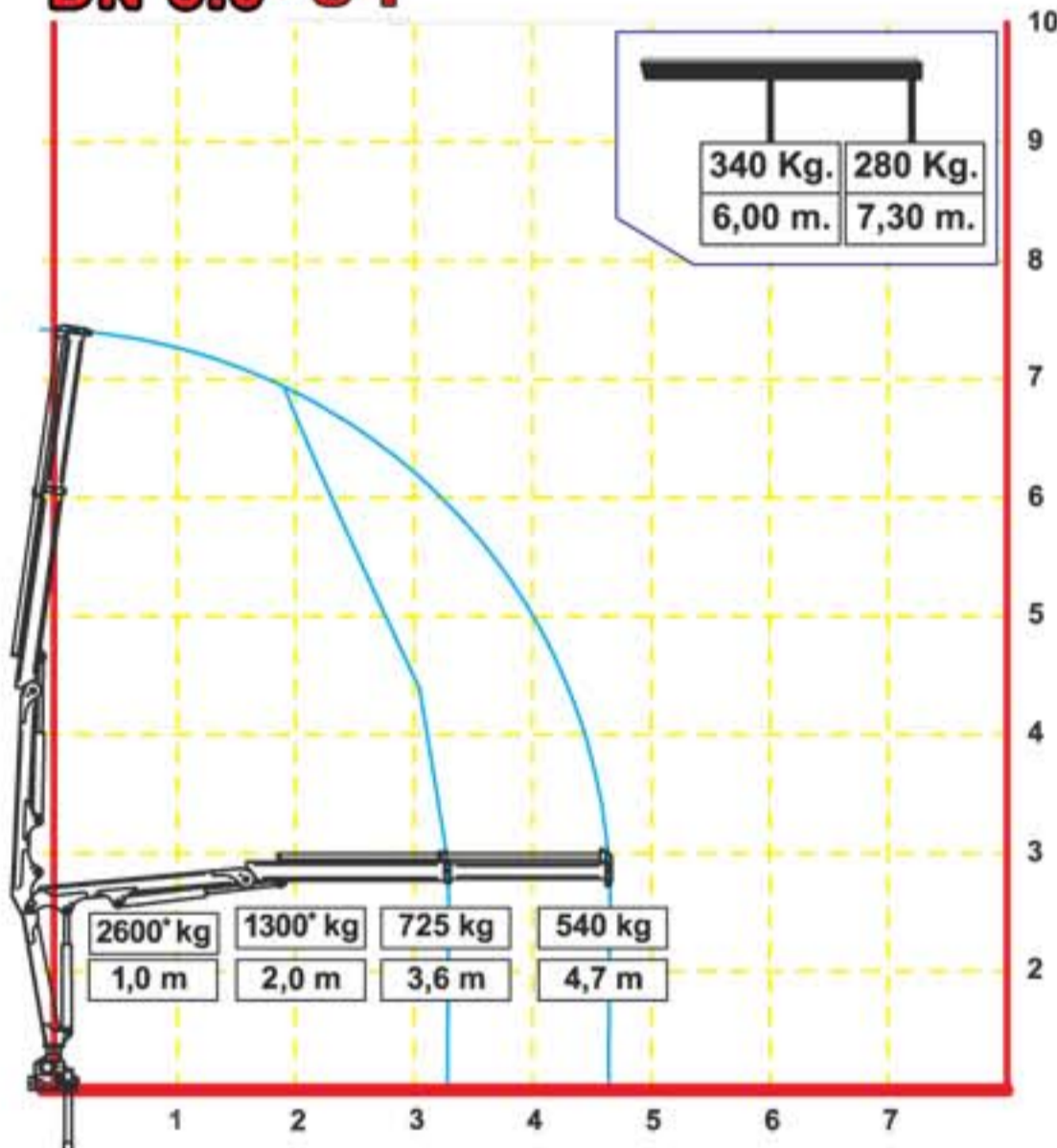

DN 3.0-S2

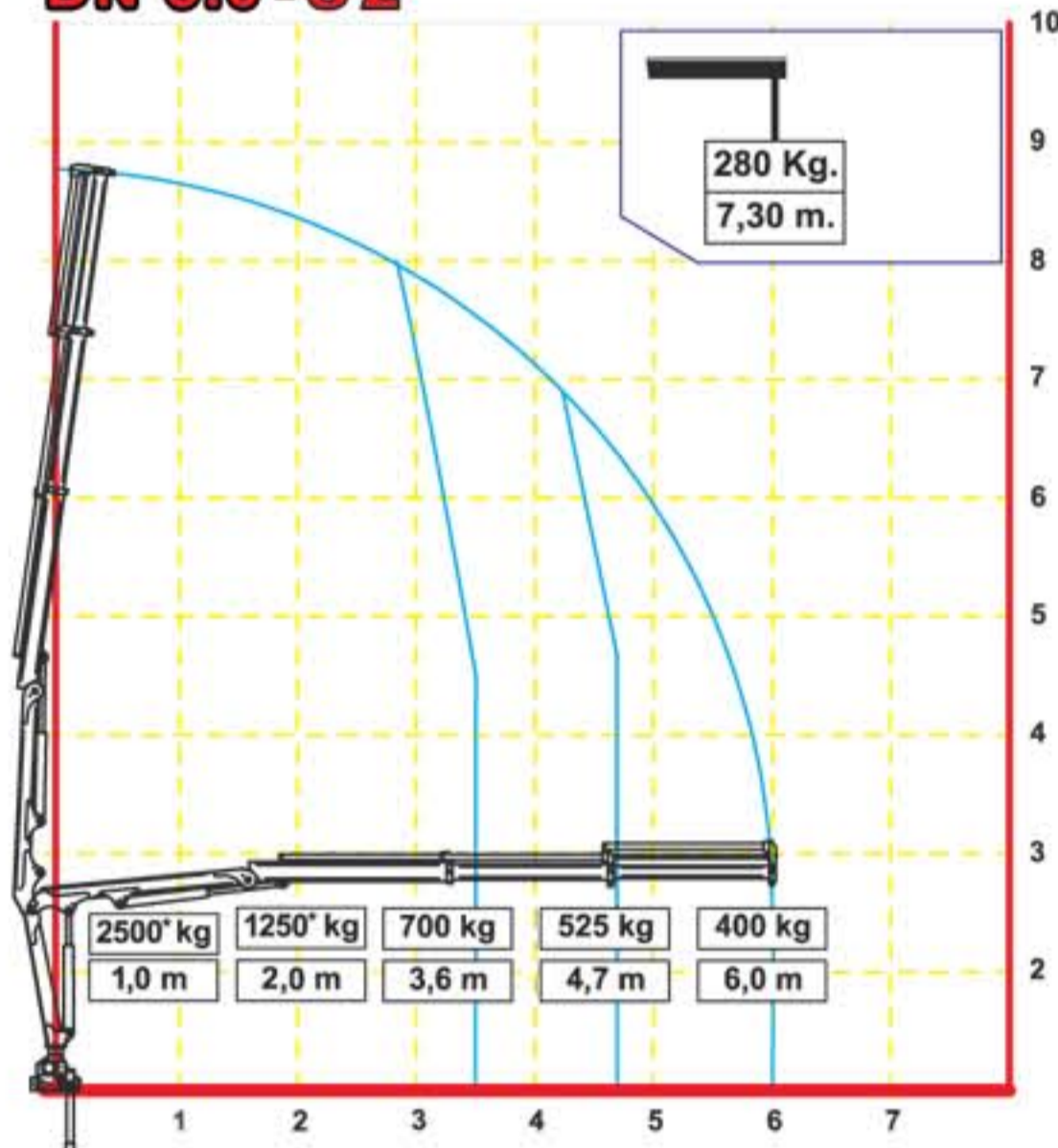

DN 3.0-S3

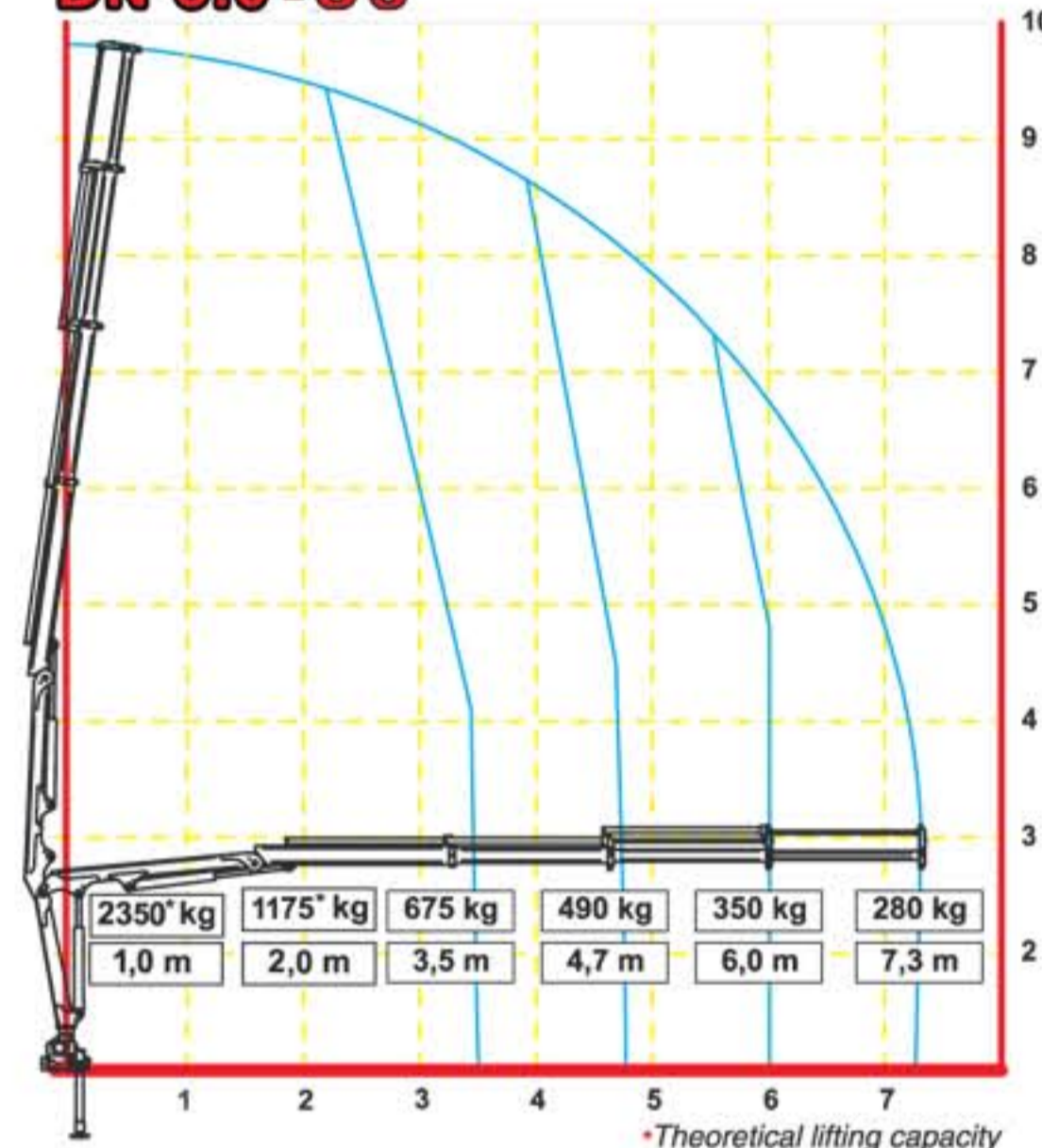

DN 3.0

S1

S2

S3

Overhung crane with empty oil tank

Peso de la grúa sin aceite en el depósito
Poids de la grue sans huile dans le réservoir
Gewichte des kranes ohne öl im tank
Massa della gru senza olio nel serbatoio

395 Kg.

415 Kg.

435 Kg.

Maximum lifting moment

Momento de elevación máximo
Moment de levage maximum
Schwenkmoment
Momento di sollevamento massimo

2.6 t/m

2.5 t/m

2.3 t/m

Hydraulic reach

Alcance hidráulico
Allongement hydraulique
Hydraulische Reichweite
Sbraccio oleodinamico

4.7 / 7.35 m

Horizontal / Vertical
Orizzontale / Vertikal

6.0 / 8.35 m

7.3 / 9.7 m

Maximum reach with manual extensions

Alcance máximo con extensiones manuales
Allongement avec rallonges manuelles
Reichweite, manuelle Verlängerungen
Sbraccio con prolunghe

7.3 / 9.75 m

Horizontal / Vertical
Orizzontale / Vertikal

7.3 / 9.75 m

DN-3.0

www.levatcranes.com
info@levatcranes.com

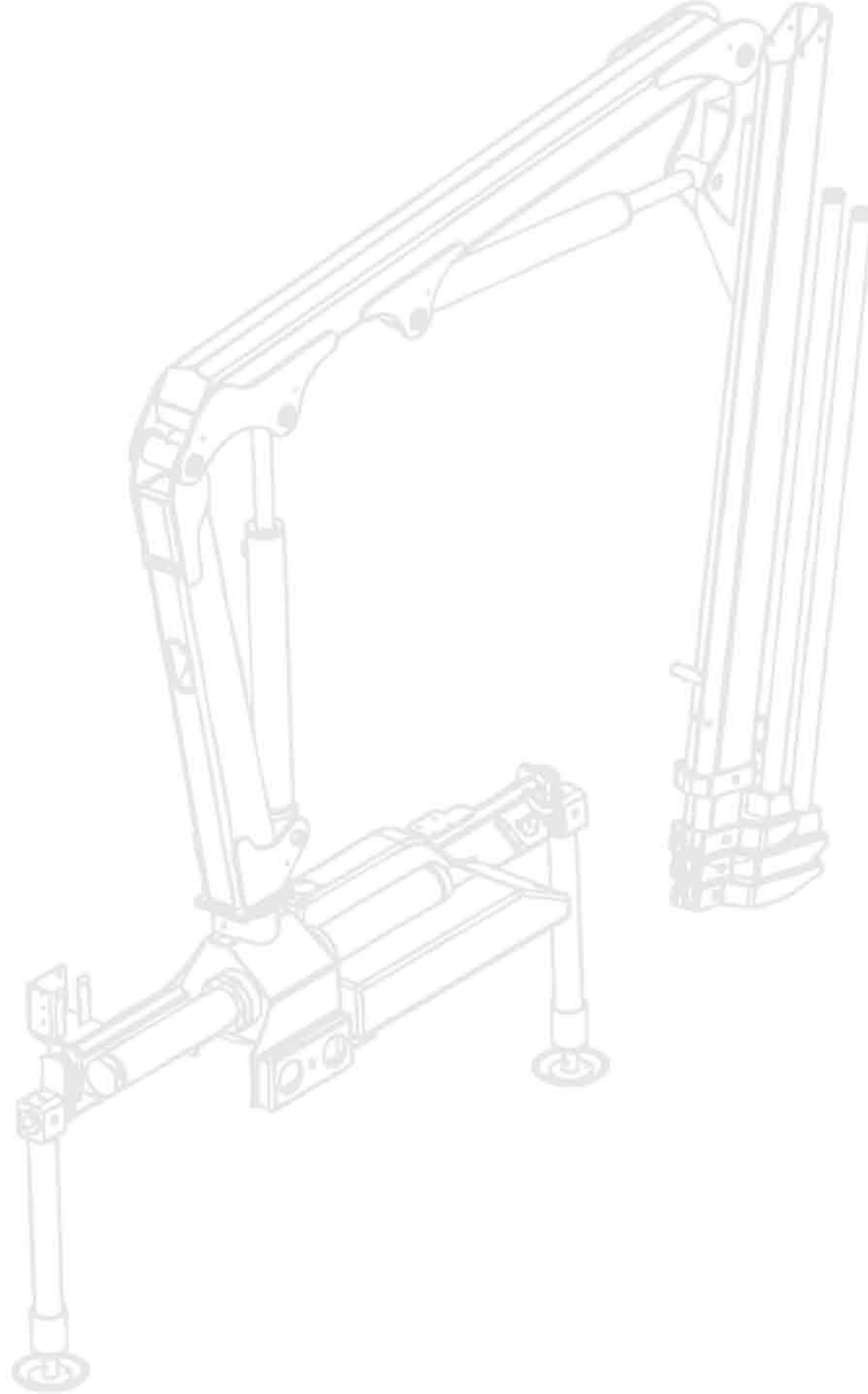

<http://www.levatcranes.com>
info@levatcranes.com

DALL'AGLIO-NORDIN GROUP

Z.I. Gerbolina
Via Tarantelli 10/12
46019 Viadana (MN)
ITALIA

Tel: +39 0375/442031
Fax: +39 0375/442032

**AMERICA
EXPEDIT INTERNATIONAL**

Calle 9 #53
Col. Seattle
Zapopan, Jalisco C.P. 45150
MEXICO

Tel/Fax: +52 33 3365-0886
Cel: +52 1 33 5331-2387

Authorized Distributor

INFOLINE: +39 333 2273773